



SUPER EIGHT

The Melbourne Film Newsthing no 32 DEC

RELATED REVIEW OF 'A PEDESTRIANS guide to COLLINGWOOD:

I WANT MY PUBLIC TV

A film that intrigued me at the last open screening was "A Pedestrians Guide to Collingwood", directed by John Jolly and starring Floyd Kermodé. The most interesting aspects of this film are its use and abuse of television news and adventure documentary formats, the extraordinary personality of the lead character and the seemingly spontaneous amusing scenarios.

The film begins with Floyd standing in Studley Park rabbiting on about how he is so poor and getting older, how he doesn't mean to complain and whether he'll get to see the "Fish that John West Reject" again (a local band). On a quiet day like this, his mind drifts to Collingwood, and soon Floyd takes up the microphone in front of his own home in Collingwood and proceeds to guide us through his environment. Some graffiti on a wall; "God is Love", "Jesus is Alive". Floyd reads this amuddle "God is Jesus is Alive" and pronounces the graffiti to be merely peoples names written on a Collingwood wall. Floyd stands in front of the old industrial shot tower and introduces it as Collingwood's oldest phallic symbol. Then a point of interest; "How on earth did someone get up there to paint an anarchist symbol on the top?"

Floyd gestures to the sky and announces "huge sumptuous black clouds hover over the skies of Collingwood putting something grey over the whole atmosphere". He interviews Meredith Moon, local resident and eccentric queen, who, when asked his opinion of his suburb, replies, "Its completely shithouse" and then flirts with the camera, wiggling his hips and blowing a kiss.

Its interesting comparing this film to Mal's Melbourne, formerly a regular segment of Eyewitness News that also attempts to unearth environmental and cultural manifestations of a city through the medium of a personality. Now Mal has a few problems, he's hellishly dull and his approach is awash with parochial sentimentality, but worst of all he subscribes to the old TV news myth of objectivity, whereby the reporter's view is obscured by clouds of innuendo and inference in the vain hope that the viewer will take this

view as being the common view. ie. Mal's experience is the common experience. The fact of the matter is that there are a myriad of different possible interpretations of an event (as many as there are people) And the fact that Mal does not cover all these is evidence that he is presenting a single, subjective interpretation. Now that would be fine, as long as you didn't pretend to have all the angles covered.

A pedestrians guide to Collingwood is the perfect foil for this kind of journalism. Floyd is remorselessly subjective in his approach; his view is his view and that's all. He is the man in the street, but by no means alludes to this as being the common experience, and this allows a real communication to be undertaken between film and viewer. For example, Floyd doesn't approve of the squatters being in the old Princess theatre and he makes this clear and Jolly emphasises this just by repeated takes of this sequence. I myself am happy about the squatters being there and I disagree with Floyd and Jolly's opinion. Thus there has been a definite exchange between film and viewer. A TV news report would definitely hedge an opinion, skirt the issue and would just fill the report with innuendo leaving the viewer with no real reference point for response. In effect this disengages the viewer, and as such is quite an effective method of de-politicising current events, something they value in trying to turn news into entertainment.

Anyway, enough of me using this film as a lever to vent my anger at the sickening rubbish we get beamed to our idiot boxes (I want my public TV) Now, let me share some of the joys of Floyd Kermodé; He stands at a busy street corner; "this is Wellington Street; sometimes, at peak hour, it can take 10 minutes to cross this street" Beautiful. Then my favourite part; Floyd returns home and he and his housemate argue the relative merits of Morrissey (from the Smiths) and Nick Cave, ending with one of them grafting Mickey Mouse's big black nose onto the stern visage of Nick Cave. Sublime.

Mark Freeman.

37TH MELBO



JUN

UNRESERVED
ADMIT ONE

8

37TH MELBO



JUNE

UNRESERVED
ADMIT ONE

6



AUSTRALIAN AIRLINES MELBOURNE CUP FINAL, 511m - 7 HUA (Storm Glade-Wanzel) R. Symes, 4 Disco Dishlicka K. Virtue, 3 Indiana T. Fletcher, 2 Plugger, 8 Gay Rajah, 5 Golden Blessing, 6 I'm Busy, 1 Sudden Storm, 2 len. 1 1/2 len. 5.90; 18.00; 30.01. New Track Record.

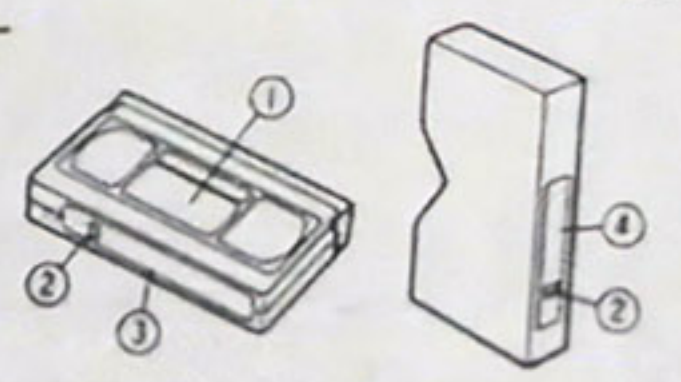

CHRISTMAS HOLIDAY SUGGESTIONS:

Write something for the Super 8 Group Year Book. Draw a picture, issue a manifesto, Exercise your vocabulary of contemporary art jargon. Win fabulous prizes for the neatest entries with correct spelling. (Send submissions to P.O. Box 1150, Richmond North 3121).

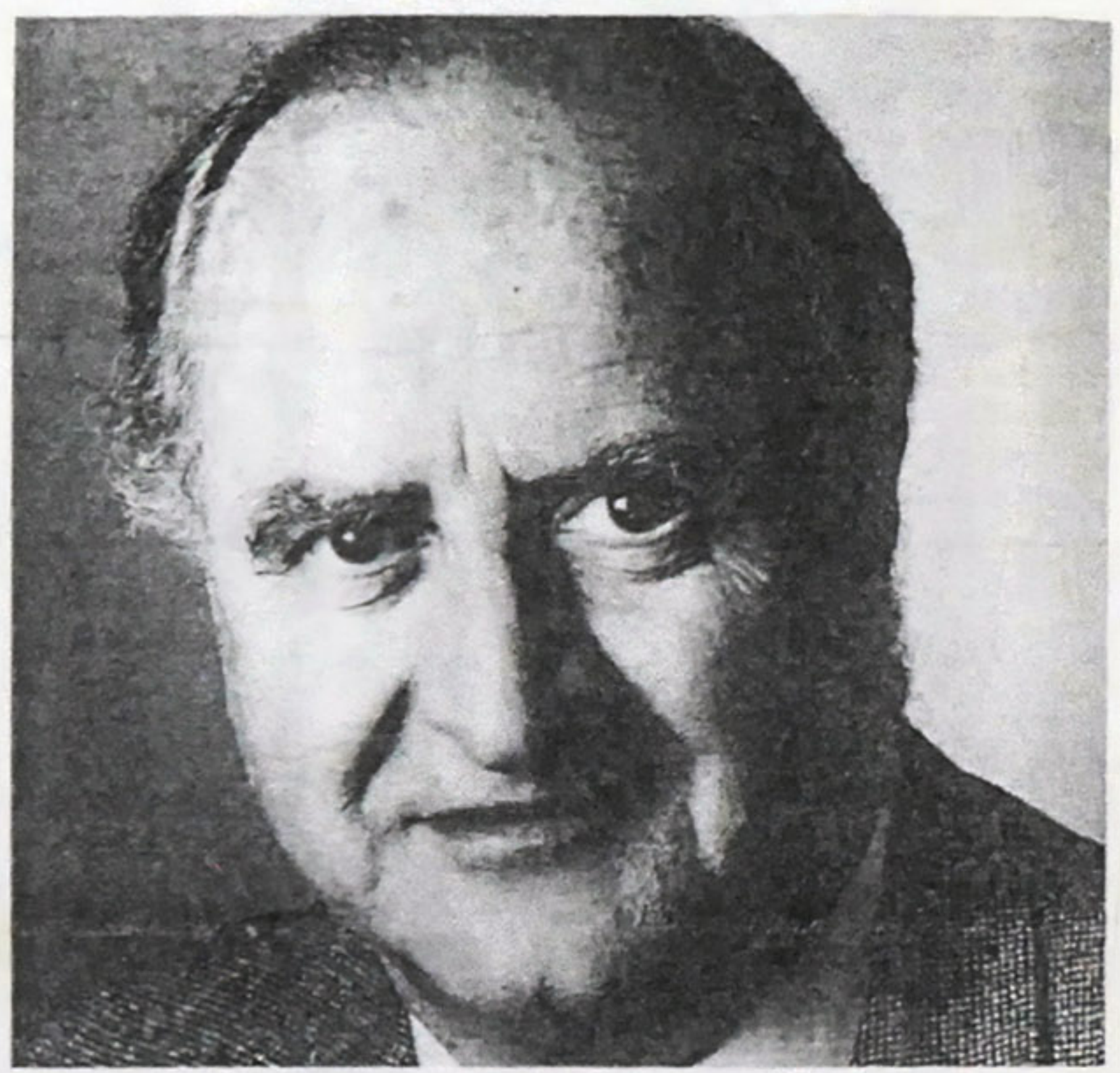

Clyde Holding replaces Gary Punch as Arts and Territories Minister. page 6

LAST OPEN SCREENING:

- 7.30 - Paul Fletcher Retrospective;
 - "Mr. Tsuzuki Comes to Australia" (1980)
 - "Elephant" (1982)
 - "Space Mutants" (1981)

8.30 - Open Screening:

- "Classic Dog Show" Chris Windmill
- "Untitled" Gail Hastings
- "Doubt" Bill Mousoulis (1982)
- "In a Lonely Place" Bill Mousoulis ('82)
- "Pandas" Ian Poppins

* * * *

A CHRISTMAS PICTURE
Noël

Le ciel est noir, la terre est blanche;
- Cloches, carillonnez gaiment! -
Jésus est né - La Vierge penche
Sur lui son visage charmant.

Théophile Gautier

* * * *

COFFEE MORNING November 15, 1988
"Tribute to Spring"

Despite freezing winds, rain on the roof, members bearing their spring posies were happy to enjoy their friends and an excellent speaker in Sally Freedman.

She married Colonel Gordon Forbes of the Indian Army and was the chatelaine of a beautiful home in Wellington where she entertained with great flair and panache. A Wellington paper reported: "At Mrs Forbes' parties there is always someone who sings, someone who plays, the flowers are always beautifully arranged and her guests always find the right people to talk to."

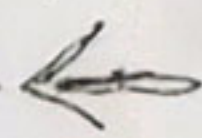

'The blame, naturally, belongs to that criminal
claimed, pointing to the mayor, who was going al
posite sidewalk on the arm of the circus impresar

DES TUDDENHAM

Birthday: 29/4/43

Height: 5' 11" Weight: 13 stone

Recruited from BALLARAT Y.C.W.

Occupation: Carpenter



Des Tuddenham

MURRAY WEIDEMAN

Birthday: 16/2/36

Height: 6' 1" Weight: 15 stone

Recruited from UNDER 19's

First Played: 1953

Games to end of 1961: 144

Occupation: Sales Representative

Interstate or Special Awards:

- 1953—Best and Fairest, Reserves.
- 1956—Interstate Representative.
- 1957—Copeland Trophy, Best and Fairest.
- 1957—Interstate Representative.
- 1958—Acting Captain, Premiership Team.
- 1961—Copeland Trophy, Best and Fairest.
- 1960—Vice-Captain, Interstate Team to Tasmania.
- 1960-61-62—Captain, Collingwood.



Murray Weideman

RAY GABELICH

Birthday: 3/7/33

Height: 6' 3½" Weight: 17 stone

Recruited from WEST AUSTRALIA

First Played: 1955

Games to end of 1961: 87

Occupation: Sales Representative

Interstate or Special Awards:

- Victorian Interstate Side, 1958, 1959, 1960, 1962.
- West Australian Side, 1961.
- Copeland Trophy, Best and Fairest, 1960.
- R. T. Rush, 2nd, Best and Fairest, 1959.



Ray Gabelich

Next Meeting

DECEMBER 13

NEXT MEETING:

Tuesday December 13 at Friends of the Earth
222 Brunswick St., Fitzroy.

- 7.30 - Annual General Meeting - Ten minutes of bureaucracy and politicking - Come early to ensure a seat.
- 7.40 - Fabulous Films from our cousins in Sydney, "Shadow of a Doubt" new from Simon Cooper, "Riff" seven film-makers working to short musical themes (rapturously received at EXPERIMENTA).
- 8.30 - Open Screening. BYO Films.
Cardboard boxes of Fine Drinking Wine will be provided.

Contact Numbers

Mark Freeman	690 9458
Sarah Johnson	534 9454
Bill Mousoulis	419 6562
Matthew Rees	201 371
Chris Windmill	531 2779

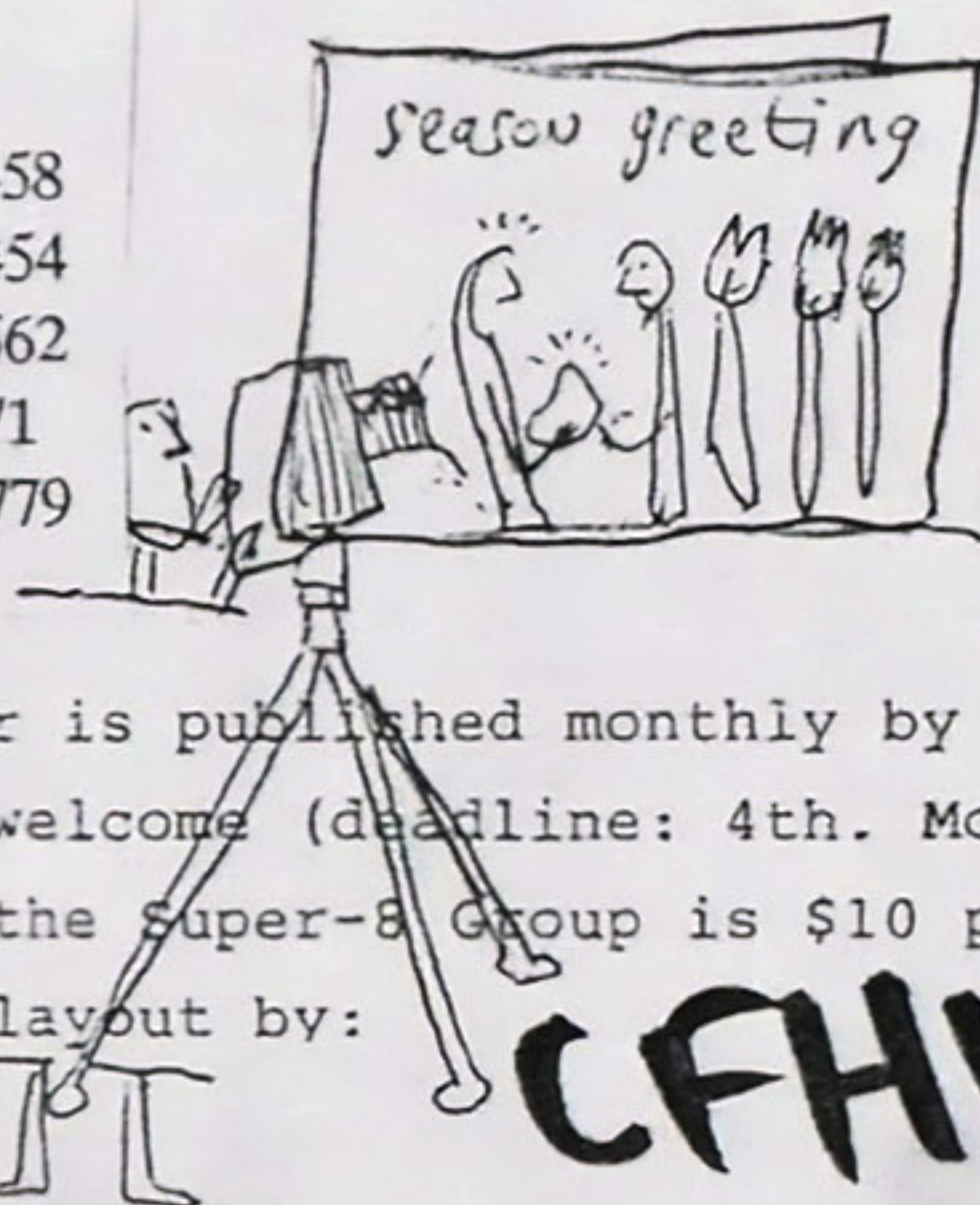

COMPILATION V-tape COMING SOON.....

This newsletter is published monthly by the Melbourne Super-8 Film Group.
Contributions welcome (deadline: 4th. Monday of each month).
Membership to the Super-8 Group is \$10 per 12 months.
Editorial and layout by:

CFHW

SUPER EIGHT

Registered by Australia Post
Publication No. vbg 7570

If undeliverable return to:
Melbourne Super-8 Film Group
P.O. Box 1150
Richmond North 3121

Postage Paid Rich. Nth Vic Aust 3121
--

Chris Windmill
6 / 158 Chapel St
Balclutha 3183